

修改序号	修改说明	签名	日期
A/0			

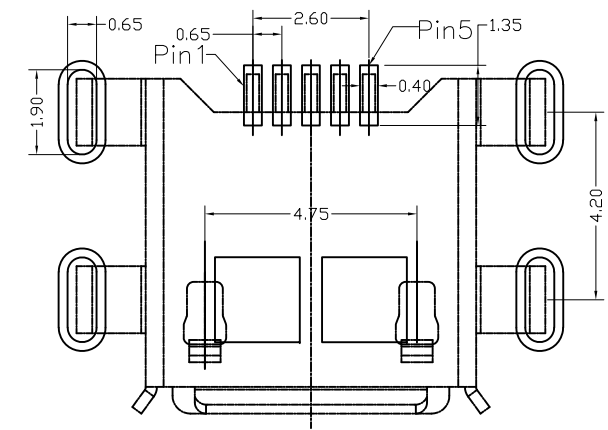

RECOMMENDED PCB LAYOUT

- Note:
- Material:
 - Housing: High temperature thermoplastic with g.f, UL94v-0
 - Contact: copper alloy, t=0.20mm
 - Shell: C2680R-H or SUS, t=0.25mm
 - Specification:
 - Current rating: 1A Max
 - Dielectric withstanding voltage: 100V(AC) for 1 min.
 - Contact resistance: 40mΩ Max.
 - Insulation resistance: 100MΩ min.
 - Total mating force: 3.57 Kgf Max.
 - Total unmating force: 1.0 Kgf Min. 0.81~2.05 Kgf Min. after 3000 or 10,000 insertion/extraction cycles
 - Temperature range: -30° C~80° C

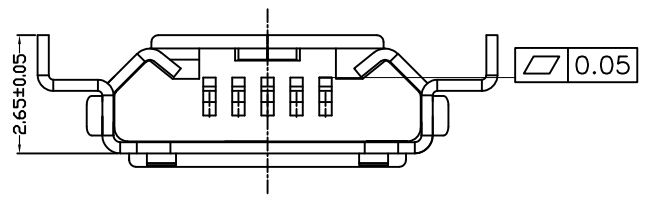
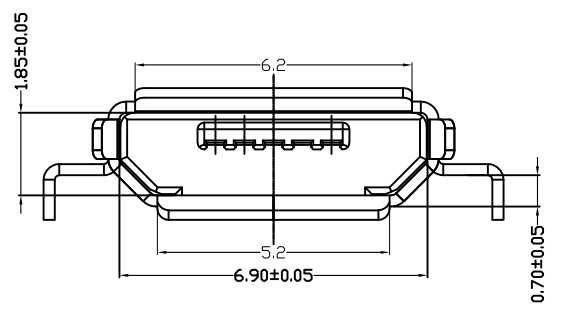
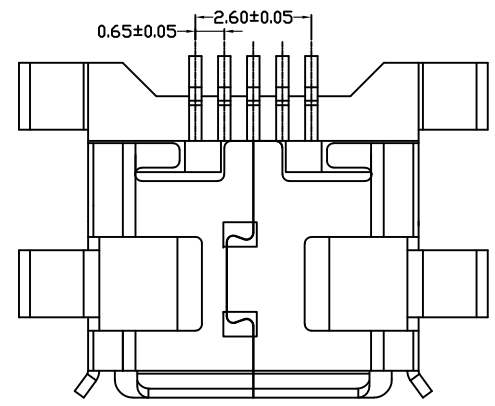
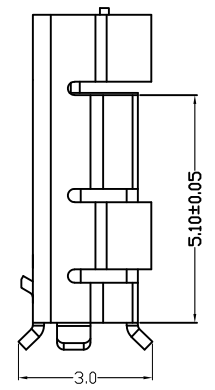
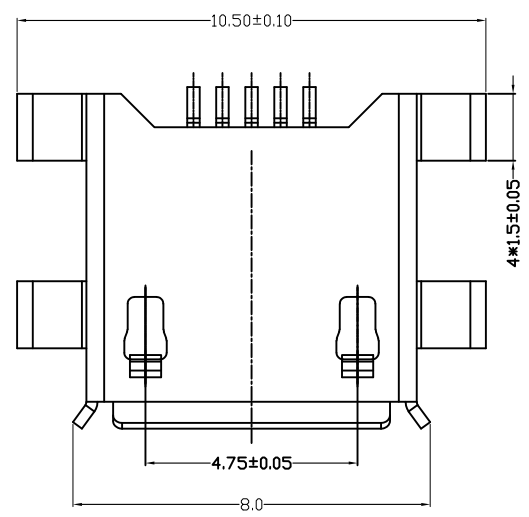

尺寸	允许公差
.X	±0.50
.X	±0.20
.XX	±0.10
.XXX	±0.03
角度	±1.00°

深圳市创勤科技有限公司
Shenzhen Chuangqin Technology Co., Ltd.

图纸类型		图纸名称:	
产品工程图		MICRO USB 5P BF 四脚带1.5插板沉板0.7	
设计	LIN YUN	2011.05.22	产品料号
审核			CQ028-MFCB05150018
		视图	
		版号:	A/0