

REV	变更内容 MODIFICATION	日期 DATE	制图 DRAW	审核 APPROVE
A	版面发行	2012/10/29	JDL	Oscar

NOTES:

ELECTRICAL:

- VOLTAGE RATING : 125 VAC RMS.
- CURRENT RATING : 1.5 AMP
- CONTACT RESISTANCE : 50 MILLIOHMS MAX.
- INSULATION RESISTANCE: 500 MEGOHMS MIN @ 500 VDC.
- DIELECTRIC STRENGTH : 1000 VAC RMS 50HZ, 1MIN.

MECHANICAL:

- HOUSING MATERIAL : GLASS FILLED POLYESTER UL94V-0
- CONTACT MATERIAL : PHOSPHOR BRONZE $\phi 0.46$ mm.
- PLATING : GOLD PLATING OVER NICKEL.
- SHIELD : COPPER ALLOY(OR STEEL ALLOY) 0.20mm THICKNESS PLATING NI.
- OPERATING LIFE : 750 CYCLES MIN.
- PCB RETENTION PRE-SOLDER : 1 LB MIN.
- PCB RETENTION POST-SOLDER: 10 LBS MIN.

ENVIRONMENTAL:

- STORAGE : -40°C TO +85°C.
- OPERATION: -40°C TO +85°C.
- ROHS COMPLIANT

MATES WITH MODULAR PLUG CONFORMING TO FCC PART 68, SUBPART F.

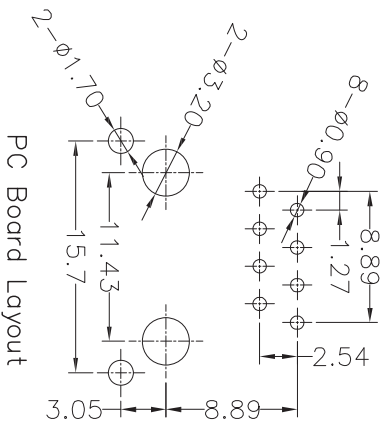
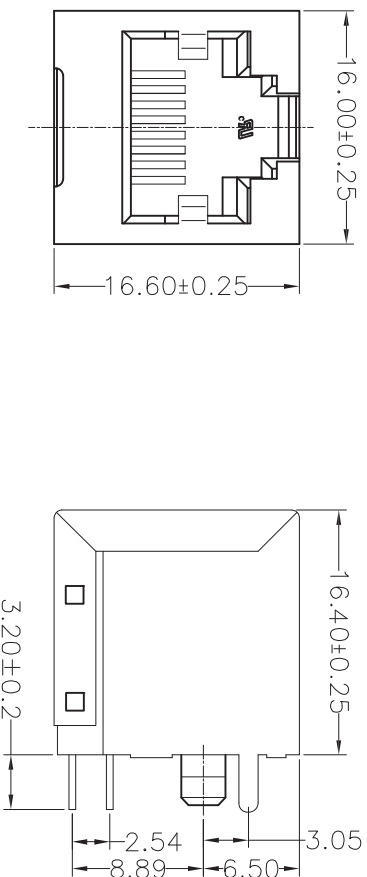

PC Board Layout

PART NUMBER: 52A-S1108C-XX

GOLD PLATING U"
 1-F^u 2-2^u 3-3^u 4-6^u
 PLASTIC MATERIAL&COLOR:Black/Yellow/Gray
 1-PR1 20X10 Black
 2-PA45 Black

Shenzhen Chuangqin Technology Co., Ltd.		深圳市创勤科技有限公司	
DIMENSION IN mm [Inch]		TOLERANCE UNLESS OTHERWISE SPECIFIED	
.X±0.20 X*±1*		.X±0.15 X*±0.5*	
.XXX±0.075		.XXX±0.075	
QC	Inspection Item	CPK	Cp/Cpk and SPC Control Item
图号	FILE NO.	图号	DWG NO.
52A-S1108C		52A-S1108C	
标题	TITLE	比例	SCALE
52A 1X1 8P8C PCB JACK WITH SHIELDED TOP ENTRY,ROUND PIN		1:1	
制图	DRAWN	审核	CHECK
Oscar		Oscar	
图框	SIZE	图框	SIZE
A3		A3	
1		1	