

RoHS Compliant

更改 REV	设计内容 MODIFICATION	日期 DATE	制图 DRAW	核准 APPROVE
A	图面发行	2012/10/29	LINYUN	ZHANG

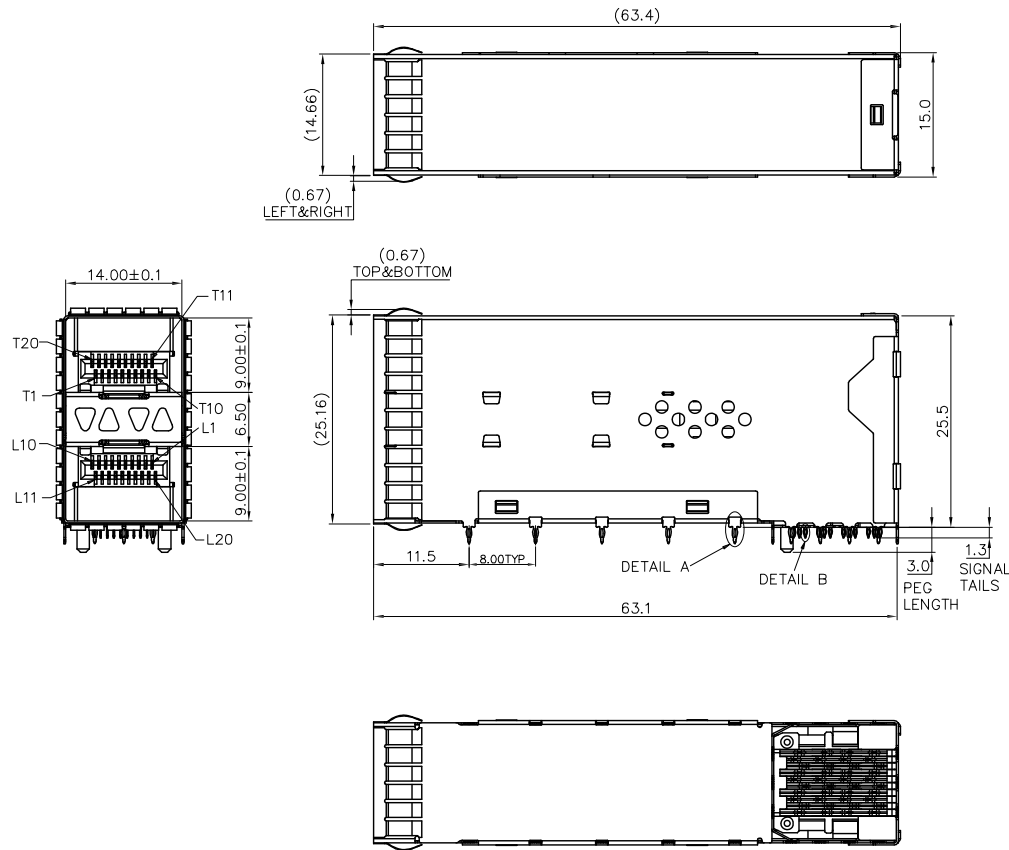

NOTES:
 1.MATERIALS:
 CAGE: COPPER ALLOY
 SPRING: COPPER ALLOY
 HOUSING: HIGH PERFORMANCE THERMOPLASTIC,94V-0.
 CONTACT: COPPER ALLOY.
 LIGHT PIPE: POLYCARBONATE.
 2.FINISH:
 CAGE: NICKEL OVERALL.
 SPRING: NICKEL OVERALL.
 CONTACT: 0.76um GOLD ON MATING END,2.54um
 MATTE TIN ON SOLDER TAIL,ALL OVER NICKEL

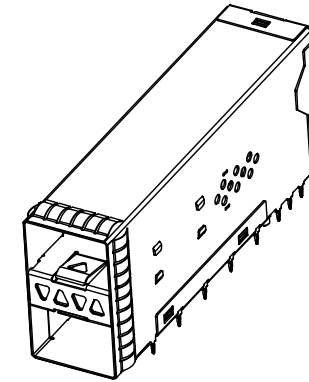
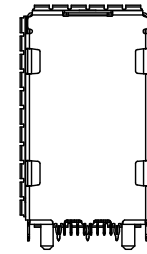

HTTPS://WWW.CHNCONN.COM		深圳市创勤电子有限公司 SHENZHEN CHUANGQIN ELECTRONICS CO., LTD.			
Inspection Item Cp/Cpk and SPC Control Item	DIMENSION IN mm [Inch]		料号 PART NO: CQ047-SFP28-2X1-L3-P0	图号 DWG NO. SFP28-2X1-GZP	
	TOLERANCE UNLESS OTHERWISE SPECIFIED		名称 TITLE SFP28 CAGE 2X1 PRESS FIT		
	.X ± 0.25	X.° ± 1°	核准 APPROVE ZHANG		
	.XX ± 0.20	.X.° ± 0.5°	审核 CHECK LIJY		
.XXX ± 0.15		制图 DRAW LINYUN	画法 PROJ. 比例 SCALE 1:1	图框 SHEET A3	页次 SHEET 1 / 1
			图框 SIZE A3	更改 REV A	

RoHS Compliant

更改 REV	设计内容 MODIFICATION	日期 DATE	制图 DRAW	核准 APPROVE
A	图面发行	2012/10/29	LINYUN	ZHANG

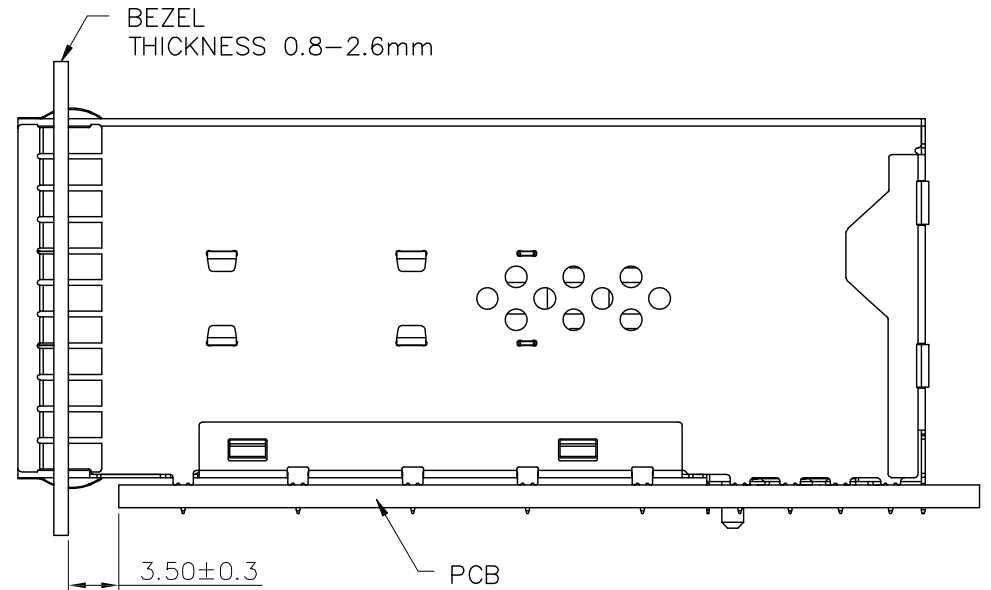
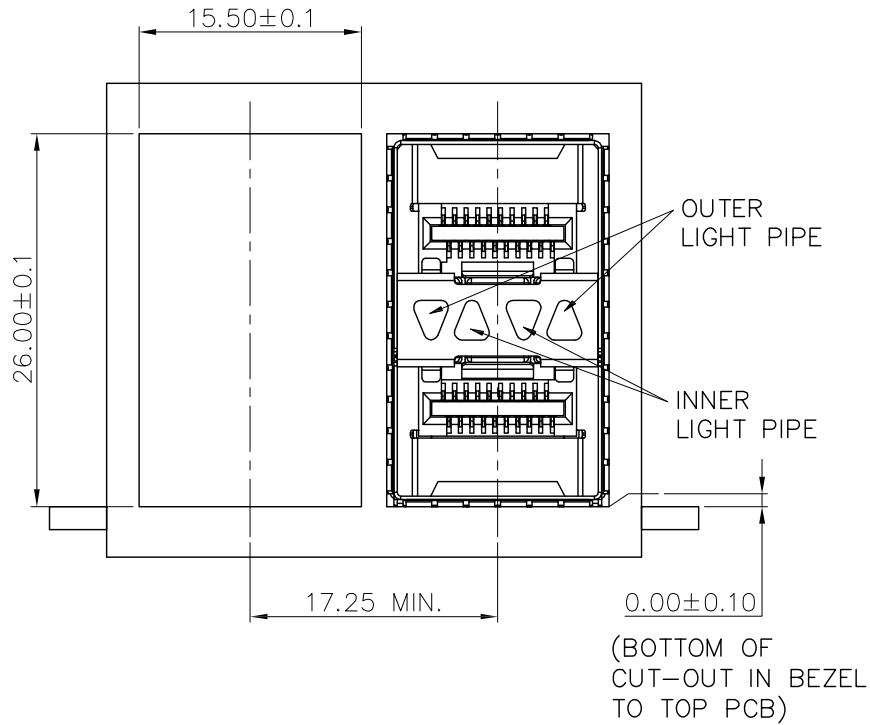

HTTPS://WWW.CHNCONN.COM		深圳市创勤电子有限公司 SHENZHEN CHUANGQIN ELECTRONICS CO., LTD.		
Inspection Item Cp/Cpk and SPC Control Item	DIMENSION IN mm [Inch]		料号 PART NO: CQ047-SFP28-2X1-L3-P0	图号 DWG NO. SFP28-2X1-GZP
	TOLERANCE UNLESS OTHERWISE SPECIFIED		名称 TITLE SFP28 CAGE 2X1 PRESS FIT	
	.X± 0.25	X.°± 1°	核准 APPROVE ZHANG	
	.XX± 0.20	.X°± 0.5°	审核 CHECK LIJY	
.XXX± 0.15		制图 DRAW LINYUN	角法 PROJ. 比例 SCALE 1:1	图框 SHEET A3
			图框 SIZE A3	页次 SHEET 1 / 2
			更改 REV A	

RoHS Compliant

更改 REV	设计内容 MODIFICATION	日期 DATE	制图 DRAW	核准 APPROVE
A	图面发行	2012/10/29	LINYUN	ZHANG

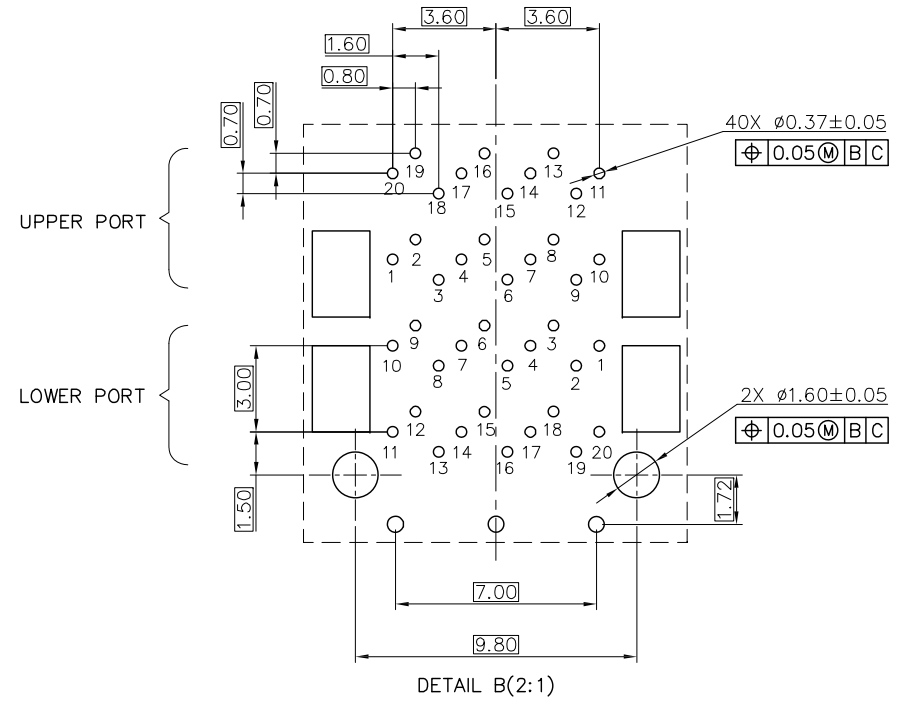
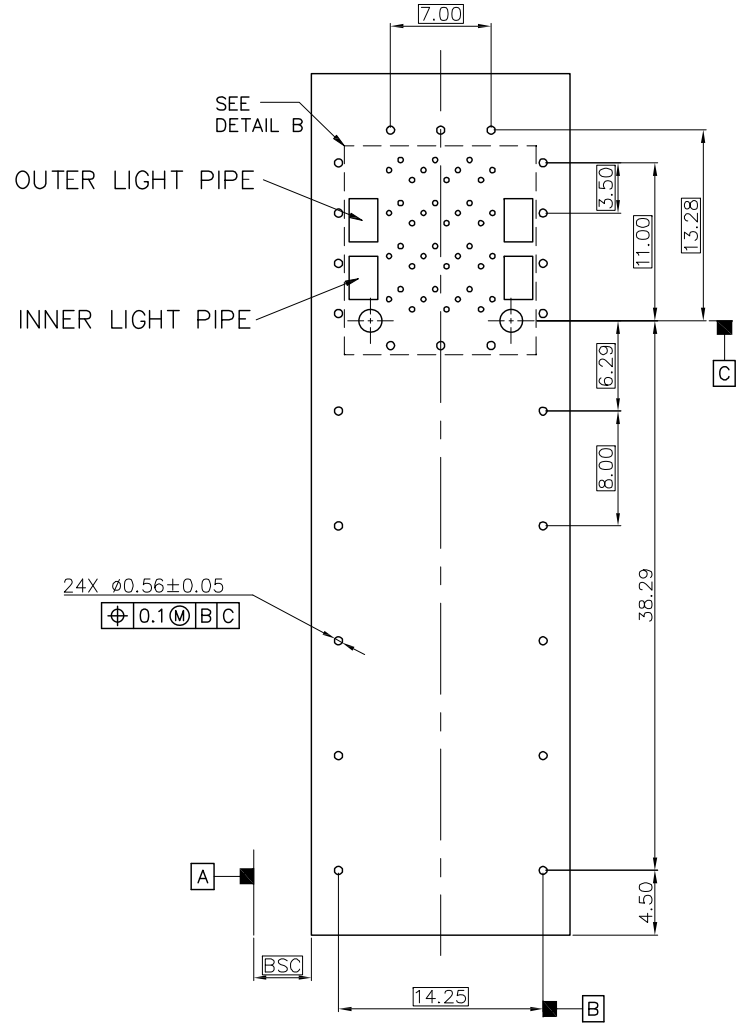

HTTPS://WWW.CHNCONN.COM		深圳市创勤电子有限公司 SHENZHEN CHUANGQIN ELECTRONICS CO., LTD.		
Inspection Item Cp/Cpk and SPC Control Item	DIMENSION IN mm [Inch]		料号 PART NO: CQ047-SFP28-2X1-L3-P0	图号 DWG NO. SFP28-2X1-GZP
	TOLERANCE UNLESS OTHERWISE SPECIFIED		名称 TITLE SFP28 CAGE 2X1 PRESS FIT	
	.X± 0.25	X.°± 1°	核准 APPROVE ZHANG	
	.XX± 0.20	.X°± 0.5°	审核 CHECK LIJY	
.XXX± 0.15		制图 DRAW LINYUN	画法 PROJ. 比例 SCALE 1:1	图框 SHEET 1 / 3
			图框 SIZE A3	更改 REV A

RoHS Compliant

更改 REV	设计内容 MODIFICATION	日期 DATE	制图 DRAW	核准 APPROVE
A	图面发行	2012/10/29	LINYUN	ZHANG

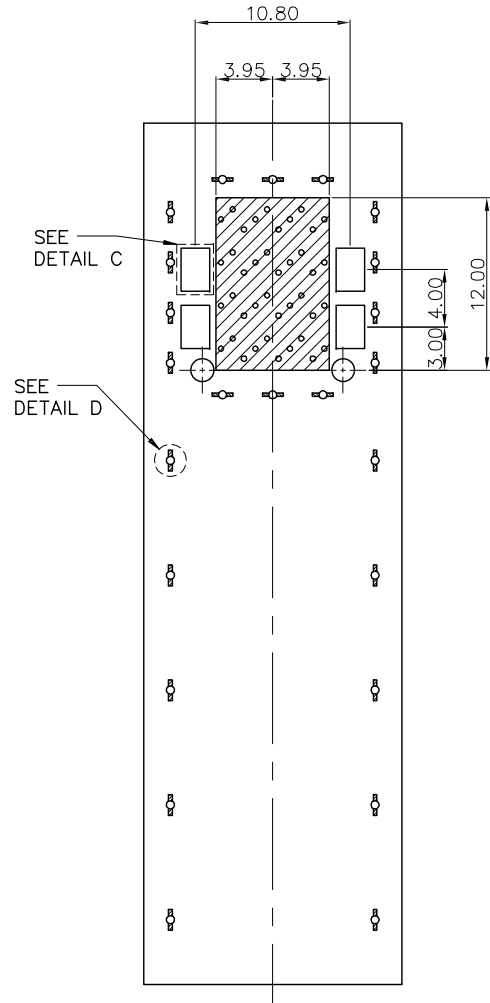

NOTE:
 3.DATUM AND BASIC DIMENSION ESTABLISHED BY CUSTOMER.
 4.THE PCB THICKNESS IS 1.6mmMIN.
 5.CROSS-HATCHED AREA DENOTES COMPONENT AND TRACE KEEP-OUT.
 6.THESE RECTANGULAR ZONES ARE FOR LED PLACEMENT. LED HEIGHT SHOULD NOT EXCEED 0.8 AND PLACEMENT SHOULD BE CENTERED WITHIN THIS LED KEEP-IN ZONE.
 7.RECOMMENDED LED CHIP PACKAGE SIZE IS 0805.

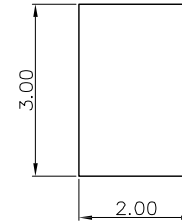

DETAIL C(4:1)
(SEE NOTE 6)

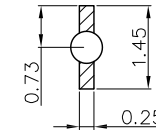

DETAIL D(4:1)

HTTPS://WWW.CHNCONN.COM		深圳市创勤电子有限公司 SHENZHEN CHUANGQIN ELECTRONICS CO., LTD.		
Inspection Item Cp/Cpk and SPC Control Item	DIMENSION IN mm [Inch]		料号 PART NO: CQ047-SFP28-2X1-L3-P0	图号 DWG NO. SFP28-2X1-GZP
	TOLERANCE UNLESS OTHERWISE SPECIFIED		名称 TITLE SFP28 CAGE 2X1 PRESS FIT	
	.X± 0.25	X.°± 1°	核准 APPROVE ZHANG	
	.XX± 0.20	.X°± 0.5°	审核 CHECK LIJY	
.XXX± 0.15		制图 DRAW LINYUN	角法 PROJ. 比例 SCALE 1:1	图框 SHEET 1 / 4 更改 REV A