

REV	变更内容 MODIFICATION	日期 DATE	制图 DRAW	审核 APPROVE
A	版面发行	2012/10/29	JDL	Oscar

NOTES:

MATERIAL:

- 1.HOUSING MATERIAL :GLASS FILLED POLYESTER(U194V-0)
- 2.CONTACT MATERIAL :PHOSPHOR BRONZE  $\phi 0.46\text{mm}$  (S5100).
- 3.PLATING :GOLD PLATING OVER NICKEL.
- 4.SHIELD COPPER ALLOY(OR STEEL ALLOY) 0.20mm THICKNESS PLATING NI.

ELECTRICAL:

- 1.VOLTAGE RATING :125 VAC RMS.
- 2.CURRENT RATING :1.5 AMP.
- 3.CONTACT RESISTANCE :50 MILLIOHMS MAX.
- 4.INSULATION RESISTANCE :500 MEGOHMS MIN @ 500V DC.
- 5.DIELECTRIC WITHSTANDING RESISTANCE :1000V AC RMS 50Hz. 1MIN.

MECHANICAL:

- 1.DURRABILITY:750 CYCLES MIN.
- 2.PCB RETENTION PRE-SOLDER

ENVIRONMENTAL:

- 1.STORAGE : -40°C TO +85°C.
  2. OPERATION : -20°C TO 70°C.
- MATES WITH MODULAR PLUG CONFORMING TO FCC PART 68,SUBPART F.

PART NUMBER: 56A-S1288L0-XX

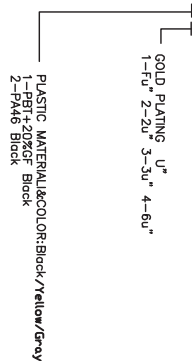
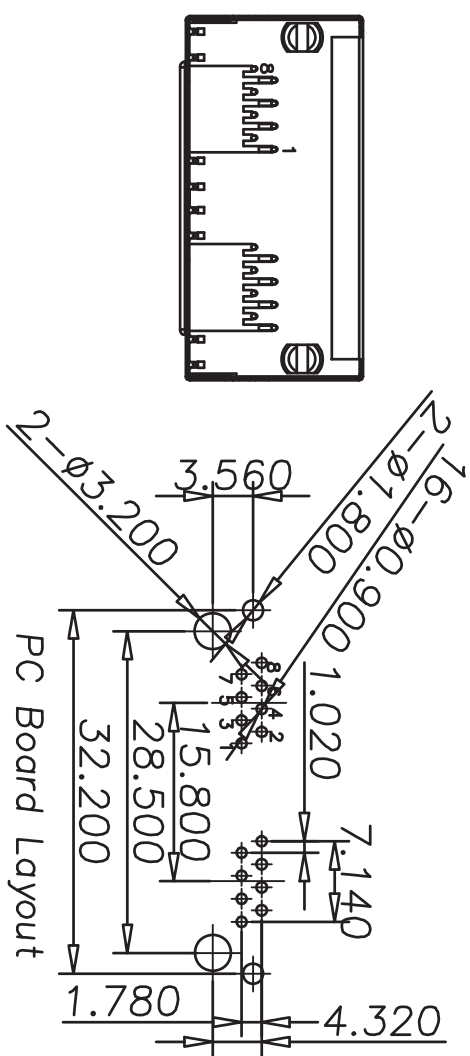
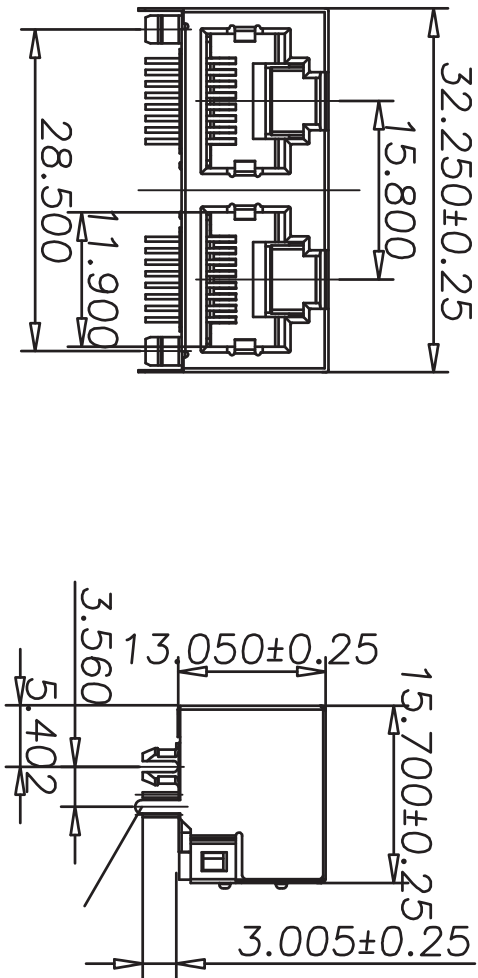

: Inspection Item		: Cp/Cpk and SPC Control Item	
DIMENSION IN mm [Inch]			
TOLERANCE UNLESS OTHERWISE SPECIFIED			
.X±0.20	X*±1*	公差	检查
.XXX±0.15	.X*±0.5*	公差	检查
.XXX±0.075		公差	检查
: Cp/Cpk and SPC Control Item			
Shenzhen Chuangqin Technology Co., Ltd.		深圳市创勤科技有限公司	
图号 FILE NO.	图号 DWG NO.	制图 DRAW	审核 CHECK
	56A-S1288L0	Oscar	
56A 1X2 8P8C PCB JACK WITH SHIELDED SIDE ENTRY,TAB-UP,ROUND PIN			
比例 SCALE	图例 SIZE	图例 SIZE	图例 SIZE
1:1	A3	A3	A