

REV.	ECN NO	LOCATIONS	DESCRIPTION	DATE

A  
B  
C  
D  
E  
F

A  
B  
C  
D  
E  
F

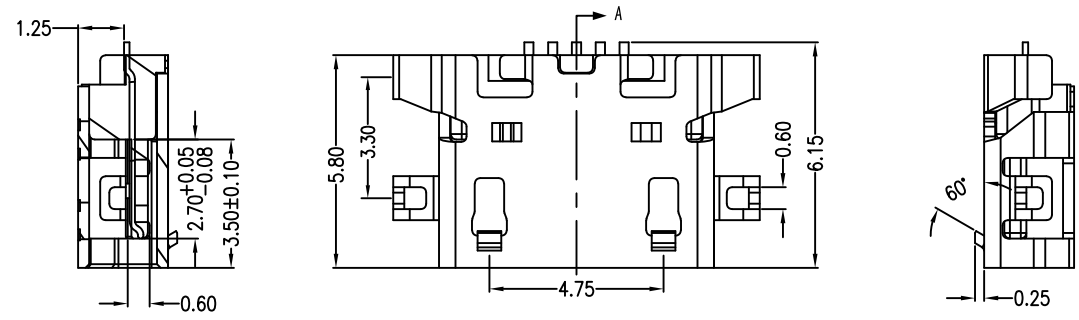
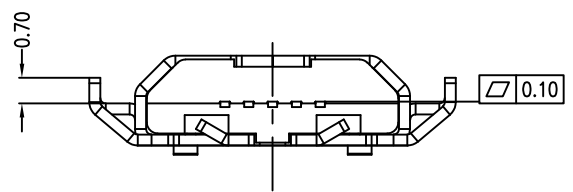

SEC A-A

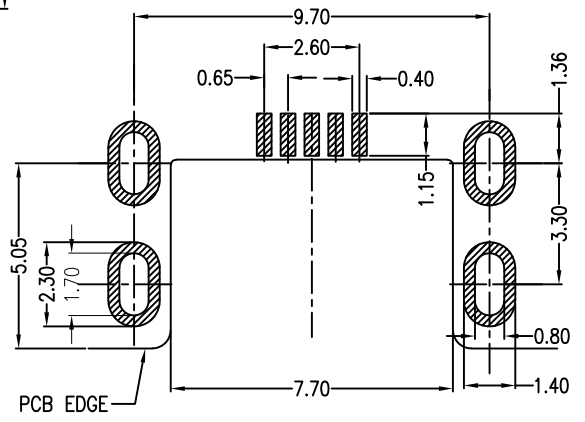
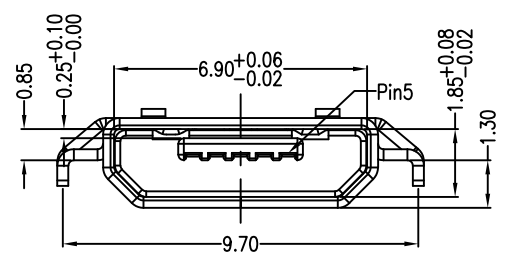

RECOMMENDED PCB LAYOUT

PCB图仅供参考

Note:

1.Material:

- 1.1 Housing: High temperature thermoplastic with g.f,UL94v-0
- 1.2 Contact: copper alloy,t=0.15mm
- 1.3 Shell: copper alloy,t=0.30mm

2.Specification:

- 2.1 Current rating:1,5PIN 1.8A Max/2,3,4PIN 1A Max.
- 2.2 Dielectric withstanding voltage: 100 V(ac) for 1 min.
- 2.3 Contact resistance: 30 mΩ Max.
- 2.4 Insulation resistance: 100 MΩ Min.
- 2.5 Total mating force: 3.57 Kgf Max.
- 2.6 Total unmating force: 1.0 Kgf Min.
- 2.7 Temperature range: -30°C~80°C

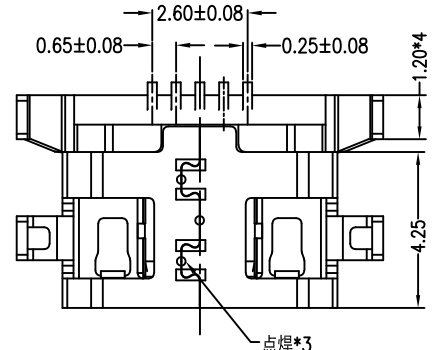

PART NO:		MATERIAL: SEE NOTE		深圳市创勤电子有限公司 SHENZHEN CHUANGQIN ELECTRONICS CO., LTD.	
MODEL NO: XX		FINISH: SEE NOTE		TITLE: Micro usb 5s B Type Smt 沉板1.3四脚全插无导位有孔 3个点焊	
UNIT: MM	SIZE: A4	COLOR: SEE NOTE		DWG NO: CQ067-MFCB05130114	REV: A
TOLERANCE UNSPECIFIED		DR: LINYUN		SCALE: 5:1	
.x 0.15		CHK: LIJY		DATE: 2014.08.09	
.xx 0.10		APP: ZHANG			
.xxx 0.05					
Ang 1°					

1 2 3 4 5 6 7 8