

更改 REV	变更内容 MODIFICATION	日期 DATE	制图 DRAW	审核 APPROVE
A	版面发行	2012/10/29	JDL	Oscar

NOTES:

MATERIAL:

- 1.HOUSING MATERIAL :GLASS FILLED POLYESTER(U194V-0).
- 2.CONTACT MATERIAL :PHOSPHOR BRONZE Ø0.46mm (C5100).
- 3.PLATING :GOLD PLATING OVER NICKEL.

ELECTRICAL:

- 1.VOLTAGE RATING :125 VAC RMS.
- 2.CURRENT RATING :1.5 AMP.
- 3.CONTACT RESISTANCE :50 MILLIOHMS MAX.
- 4.INSULATION RESISTANCE :500 MEGOHMS MIN @ 500V DC.
- 5.DIELECTRIC WITHSTANDING RESISTANCE :1000V AC RMS 50Hz. 1MIN.

MECHANICAL:

- 1.DURRABILITY :750 CYCLES MIN.
- 2.PCB RETENTION PRE-SOLDER :1 LB MIN.

ENVIRONMENTAL:

- 1.STORAGE :-40°C TO +85°C.
 2. OPERATION : 0°C TO 70°C.
- MATES WITH MODULAR PLUG CONFORMING TO FCC PART 68,SUBPART F.

PART NUMBER: 5222-N1166-XX

GOLD PLATING "U"
1-"Ø" 2-"2U" 3-"3U" 4-"6U"
PLASTIC MATERIAL:COLOR:Black/Yellow/Gray
1-PBT+20%GF Black
2-PBT+20%GF Gray

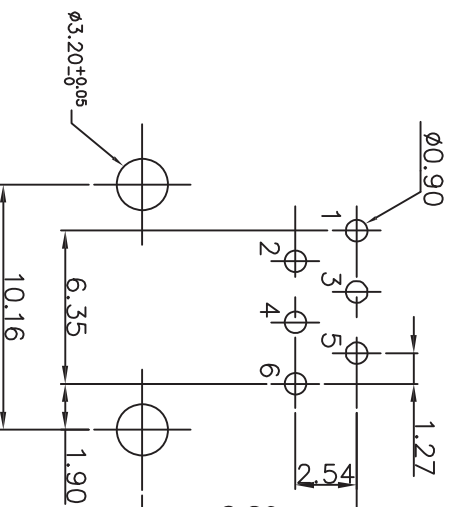
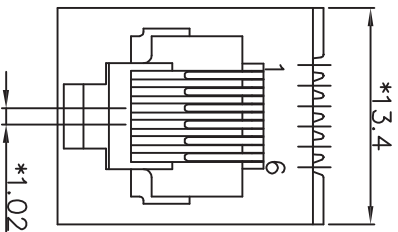
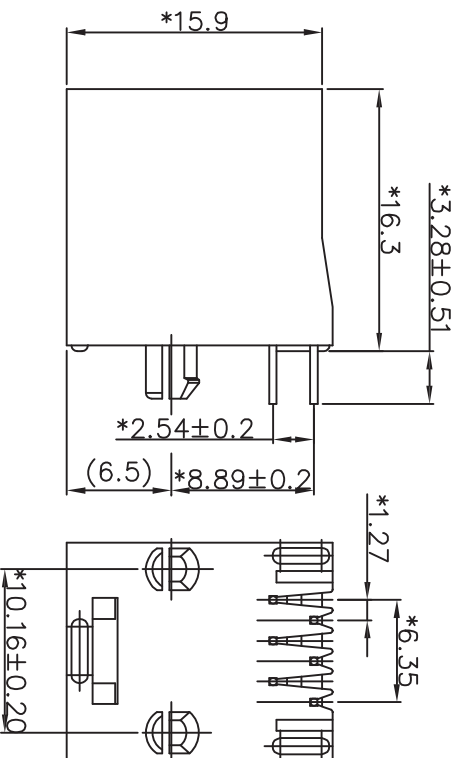

PC Board Layout
Component Side Shown
Dimension Tolerance: ±0.05

:Inspection Item		:Cp/Cpk and SPC Control Item	
QC		CPK	
DIMENSION IN mm [Inch]		TOLERANCE UNLESS OTHERWISE SPECIFIED	
.X±0.20	X*±1"	.XX±0.15	*X±0.5"
.XXX±0.075		.XXX±0.075	
批准 APPROVE	检查 CHECK	制图 DRAW	审核 SCALE
Shenzhen Chuangqin Technology Co., Ltd.		深圳市创勤科技有限公司	
文件号 FILE NO.		图号 DWG NO.	
5222-N1166		5222-N1166	
标题 TITLE		5222 1X1 6P6C PCB JACK W/O SHIELD SIDE ENTRY,ROUND PIN	
Oscar		1:1	
		A3	
		1	
		A	